



ELECTRIC OFF-ROAD BICYCLE

PRODUCT MANUALS

PRODUCT MANUALS

Before using our products, be sure to read this statement carefully. If the use of our products occurs, you will be deemed to have understood and recognised the full contents of this statement.

1. When you use this product, be sure to comply with national laws and regulations and local traffic rules because of the violation of the above laws and regulations and any consequences caused by the company is not responsible.
2. Be sure to bring all the relevant documents before riding to avoid unnecessary trouble our company is not responsible.
3. This vehicle is equipped with a safe line insurance device must not be unauthorised to change or replace the fault caused by our company is not responsible.
4. When you buy this product, please check all the data on the voucher, and keep all the vouchers after the completion of the purchase. Because the data does not match the real thing or the voucher is not complete and other reasons for the user, the consequences of which the user is solely responsible for.
5. you use this product before, be sure to carefully read the instructions; in the use of this product, in strict accordance with the instructions in the use of the corresponding operation. The company is not responsible for any consequences caused by improper use or speeding, overloading and other reasons!
6. The right of interpretation of this statement belongs to our company.

- * Please read this manual carefully before using the EKX e-bike.
- * Please keep the original packaging of the bike for repackaging when returning or replacing the product.
- * Please refer to the instruction manual to install the bike correctly and check if any screws are loose.

PREFACE

Part 1 Before You Ride	3-9
Part 2 Bicycle Product Details	10-22
Part 3 Electronics and batteries	23-26
Part 4 Assembling the components	27-40
Part 5 Maintenanceand repair	41-44

1. BEFORE YOU RIDE

ABOUT THIS MANUAL

It is important for you to understand your new bicycle. By reading this manual before you go out on your first ride, you'll know how to get better performance, comfort, and enjoyment from your new bicycle.

It is also important that your first ride on your new bicycle is taken in a controlled environment, away from cars, obstacles, and other cyclists.

GENERAL WARNING

Bicycling can be a hazardous activity even under the best of circumstances. Proper maintenance of your bicycle is your responsibility as it helps reduce the risk of injury. This manual contains many "Warnings" and "Cautions" concerning the consequences of failure to maintain or inspect your bicycle. Many of the warnings and cautions say "you may lose control and fall" Because any fall can result in serious injury or even death, we do not repeat the warning of possible injury or death wherever the risk of falling is mentioned.

A SPECIAL NOTE FOR PARENTS

It is a tragic fact that most bicycle accidents involve children. As a parent or guardian, you bear the responsibility for the activities and safety of your minor child. Among these responsibilities are to make sure that the bicycle which your child is riding is properly fitted to the child; that it is in good repair and safe operating condition; that you and your child have learned, understand and obey not only the applicable local motor vehicle, bicycle, and traffic laws, but also the common sense rules of safe and responsible bicycling. As a parent, you should read this manual before letting your child ride the bicycle. Please make sure that your child always wears an ANSI, ASTM, SNELL approved bicycle helmet when riding.



Fully charge the battery before first use - Batteries should be fully charged immediately when they are received and immediately after each use for the recommended charge times (see below)

- Li-Ion (Lithium Ion) batteries 4-6 hours

We recommend that you consult a bicycle specialist if you have doubts or concerns as to your experience or ability to properly assemble, repair, or maintain your bicycle.

Additional warning/cautions are in the assembly section of this manual.

With proper care and maintenance Electric Bicycle will provide ease of use and be fun to ride. Below are points that will help you to maximize the enjoyment you get from your new hybrid electric bicycle

Factors that maximize e-bike range

- **Rider input** - the more the rider pedals the further the distance traveled. Continuous riding, as opposed to frequent stopping and starting, will yield the greatest range possible
- **Elevation Gain** - the flatter the road the further the distance traveled
- **Weather** - cold weather can adversely affect the battery capacity
- **Wind** - traveling with a tailwind will increase distance traveled, traveling into a headwind will decrease distance traveled
- **Terrain** - the smoother the terrain (roadways vs. fire roads, etc,) the further the distance traveled
- **Ride R Weight** - the lighter the rider, resulting in less drain on the batteries, the further distance traveled
- **Bicycle Maintenance** - a properly maintained bicycle will yield the greatest range possible
- **Tire Pressure** - properly inflated tires have less rolling resistance and will be easier to pedal
- **Batteries** - properly charged and maintained batteries will yield the greatest range possible. Batteries stored in cold areas (below 50 degrees Fahrenheit / 10 degrees Celsius) will show reduced range. Batteries that have not been kept in optimum condition will show reduced range and run time

Your new bicycle was partially assembled in the factory and then partially disassembled for shipping. You may have purchased the bicycle already fully assembled and ready to ride OR in the shipping carton in the partially disassembled form. The following instructions will enable you to prepare your bicycle for years of enjoyable cycling. For more details on inspection, lubrication, maintenance and adjustment of any area please refer to the relevant sections in this manual. If you have questions about your ability to properly assemble this unit, please consult a qualified bicycle service specialist before riding. If you need replacement parts or have questions pertaining to assembly of your bicycle, call the service line direct at:

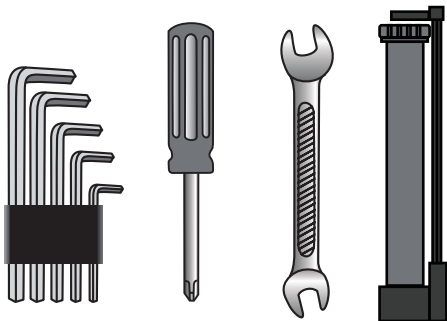

Typical Tools Required:

- Hexagon screwdriver 2mm,3mm,4mm,5mm,6mm
- Phillips head screw driver
- wrench
- bicycle pump

When working on your bicycle as instructed by this manual, please refer to the torque values chart on pages 120-121 for detailed torque requirements. Under or over-tightened components may loosen or break, causing a fall.

SAFETY CHECKLIST

Before every ride, it is important to carry out the following safety checks:



1.Brakes

- Ensure front and rear brakes work properly.
- Ensure brake shoe pads are not over worn and are correctly positioned in relation to the rims.
- Ensure brake control cables are lubricated, correctly adjusted and display no obvious wear.
- Ensure brake control levers are lubricated and tightly secured to the handlebar.



2.Wheels and tires

- Ensure tires are inflated to within the recommended limit as displayed on the tire sidewall.
- Ensure tires have tread and have no bulges or excessive wear.
- Ensure rims run true and have no obvious wobbles or kinks.
- Ensure all wheel spokes are tight and not broken.
- Check that axle nuts are tight, If your bicycle is fitted with quick release axles, make sure locking levers are correctly tensioned and in the closed position.



3.Steering

- Ensure handlebar and stem are correctly adjusted and tightened, and allow proper steering.
- Ensure that the handlebars are set correctly in relation to the forks and the direction of travel.
- Check that the headset locking mechanism is properly adjusted and tightened.
- The If bicycle is fitted with handlebar end extensions, ensure they are properly positioned and tightened



4.Chain

- Ensure chain is oiled, clean and runs smoothly.
- Extra care is required in wet or dusty conditions.

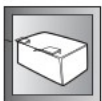

5. Battery Pack

- Ensure the batteries are in good operation condition and kept fully charged.



6. Bearings

- Ensure all bearings are lubricated, run freely and display no excess movement, grinding or rattling.
- Check headset, wheel bearings, pedal bearings and bottom bracket bearings.



7. Cranks and Pedals

- Ensure pedals are securely tightened to the cranks
- Ensure cranks are securely tightened to the axle and are not bent.



8. Derailleurs

- Check that front and rear mechanisms are adjusted and function properly.
- Ensure shift and brake levers are attached to the handlebar, shift and brake.
- Ensure derailleurs, shift levers and shift and brake cables are properly lubricated.



9. Frame and Fork

- Check that the frame and fork are not bent or broken
- either If are bent or broken, they should be replaced.



10. Accessories

- Ensure that all reflectors are properly fitted and not obscured.
- Ensure all other fittings on the bike are properly and securely fastened, and functioning.
- Ensure the rider is wearing a helmet.

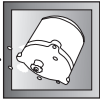

11. Motor Drive Assembly and Throttle

- Ensure all motor drive components are correctly mounted and functioning properly

HELMETS SAVE LIVES!!!

ALWAYS WEAR A PROPERLY FITTED HELMET WHEN YOU RIDE YOUR BICYCLE.

DO NOT RIDE AT NIGHT.

CPSC RECORDS SHOW THAT ABOUT 35% OF BICYCLE RELATED DEATHS OCCUR AFTER DARK.

AVOID RIDING IN WET CONDITIONS.

CPSC RECORDS SHOW THAT ABOUT 65% OF INJURIES.

HAPPEN TO CHILDREN UNDER 15 YEARS OF AGE.

RIDE ONLY WITH ADULT SUPERVISION

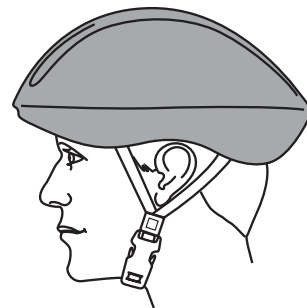

CORRECT FITTINGMAKE SURE
YOUR HELMET COVERS YOUR
FOREHEAD

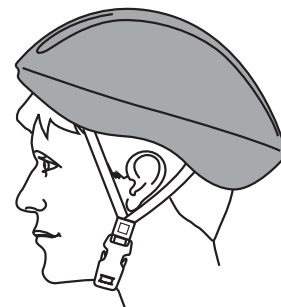

INCORRECT FITTING.FOREHEAD
IS EXPOSED AND VULNERABLE
TO SERIOUS INJURY.

**Please Retain your Sales Receipt as Proof of Purchase.
Attach receipt here.**

Notes: _____

2、BICYCLE PRODUCT DETAILS

GTS SERIES ELECTRIC BICYCLE





LCD Screen Display
Indication of mileage speed, mileage,
gear, headlight and PAS.
Fault Warning.
Function setting, etc

Brake Lever

Accelerator

Gear increase Button

Gear Reduction Button

P button

Ambient light switch

Power off Switch Line

Brake Cable

Accelerate button

Power Switch

Deceleration button

Horn

F*R Light Switch

INTRODUCTION OF ELECTRIC VEHICLE PARTS



X21 SERIES ELECTRIC BICYCLE





Brake Lever

Accelerator

Gearincrease Button

Gear Reduction Button

LCD Screen Display
Indication of mileage speed, mileage,
gear, headlight and PAS.
Fault Warning.
Function setting, etc

Power off Switch Line

Brake Cable

- Setting Button
- F+R Light Switch
- Power Switch
- Horn
- L&R turn signal switch
- Electric Speed Button

INTRODUCTION OF ELECTRIC VEHICLE PARTS



X21-MAX SERIES ELECTRIC BICYCLE





Brake Lever

Accelerator

Gear Increase Button

Gear Reduction Button

P button

High and low speeds

LCD Screen Display
Indication of mileage speed, mileage,
gear, headlight and PAS.
Fault Warning.
Function setting, etc

Power off Switch Line

Brake Cable

Horn
F*R Light Switch

INTRODUCTION OF ELECTRIC VEHICLE PARTS



X20 SERIES ELECTRIC BICYCLE





Brake Lever

Accelerator

Gear Increase Button

Gear Reduction Button

LCD Screen Display
Indication of mileage speed, mileage,
gear, headlight and PAS.
Fault Warning.
Function setting, etc

Power off Switch Line

Brake Cable

- Setting Button
- F* R Light Switch
- Power Switch
- Horn
- L&R turn signal switch
- Electric Speed Button

INTRODUCTION OF ELECTRIC VEHICLE PARTS



PRODUCT SPECIFICATIONS

Model	Wheel size	Motor	Battery	Max speed	Riding distance	Load-bearing
GTS	70/100-19	8000W	72V 30Ah	85km/h	100km	150 KG
X21	20*4.0	2000W	48V 35Ah	55km/h	150km	150 KG
X21-MAX	70/100-19	3000W	60V 30Ah	55km/h	150km	150 KG
X20	20*4.0	2000W	48V 30Ah	55km/h	120km	150 KG

- ★ The above values are the highest peak values derived from laboratory practice for electric vehicles.
- ★ The maximum speed and mileage are determined by factors such as the rider's weight, the artificial power provided by the rider with the assistance of pedals, the friction of different grounds, and whether the battery is fully charged or not.

3. ELECTRONICS AND BATTERIES

THROTTLES

Throttles are equipped on some models of electric bicycles. Throttles operate by rotating the throttle towards the rider much like a motorcycle. They generally are the inner half of the right side handlebar grip and may also contain a battery gauge. The more you twist the throttle, the faster the motor system will propel the bicycle.

TAG(TWIST AND GO)

Before you begin riding, turn the main power switch on, then start riding as you would ride any regular, non motor assisted bicycle. After you have begun to ride, slowly twist the throttle (on equipped models) towards you. The more you twist the throttle, the more motor power will be applied to the wheels. You may feel the pedals get a “lighter” feel than when riding without the motor assisting you. Once you have twisted the throttle all the way, the motor will accelerate you to its full speed of about 18-20mph (28-32 km/h). Begin by first riding as if you are on a normal non-electric bicycle. After a few seconds, the motor will slowly activate and ramp up to 50% power. Then, while the pedals are in motion, you can slowly twist the throttle towards you to activate the full motor power.

Meter display error code definition table. All error codes are uploaded from the controller to the instrument except for communication errors which are reported by the instrument on its own initiative, and the instrument is only responsible for displaying them.



Trouble code	Fault name	Possible causes
E021	Abnormal current	1、 Damaged or abnormal controller MOS
E022	Rotor fault	1、 Turnbuckle not returned to position 2、 Turnbuckle not connected 3、 Turnbuckle damaged
E023	Motor phase failure	1、 The motor phase wires are not connected properly or are connected incorrectly 2、 The motor phase wires are shorted to each other
E024	Hall Failure	1、 Damaged motor hall 2、 Misconnected or unconnected hall wires
E025	Brake Failure	1、 Brake not returned to position 2、 Brake not connected or damaged
E030	Communication Failure	1、 Meter and controller communication wire harness definition is reversed or there is a broken wire in the harness 2、 Controller and meter protocol mismatch 3、 Meter communication circuit is burned out

Battery Care and Information

Proper maintenance of batteries will maximize their lifespan and capacity. Currie Ruli vehicle warranties your new batteries from the date of purchase only if properly cared for—refer to the limited warranty for details. Ruli uses Li-Ion (Lithium Ion) batteries in all of our electric bicycles and scooters. These are both very user-friendly types of batteries when cared for properly.

Care

Even with proper care, rechargeable batteries do not last forever. Every time the battery is discharged and subsequently recharged, its relative capacity decreases by a small percentage. You can maximize the life of your battery by following the instructions in this guide.

- Batteries should be fully charged immediately when they are received for the full recommended charge times
Li-Ion recommended charge time: 4-6 hours For a complete, 100% charge, leave the battery on the charger for one full hour after the charger indicator light turns green.
- Never charge batteries for longer than 24 hours.
- Li-Ion batteries do not have a "memory." Partial discharge/charge cycles will not harm the batteries' capacity or performance.
- The rated output capacity of a battery is measured at 77°F (25°C). Any variation in this temperature will alter the performance of the battery, and shorten its expected life. High temperatures especially reduce overall battery life & runtime.
- Currie bikes and scooters are equipped with a five-minute sleep function. If no activity is detected after five minutes, the bike/scooter will go into "stasis" mode to conserve battery power. Simply cycle the bike/scooter off then on again to re-activate the battery.
- Always be sure to turn the bike/scooter power switch to "OFF" after each use. If you leave the power switch in the "ON" position, or your product has not been charged for a long period of time, the batteries may reach a state at which they will no longer hold a charge.
- Be friendly to the environment! Be sure to recycle your old batteries at a local battery-recycling center. Do not throw them in the garbage!

• Do not charge the battery indoors! 

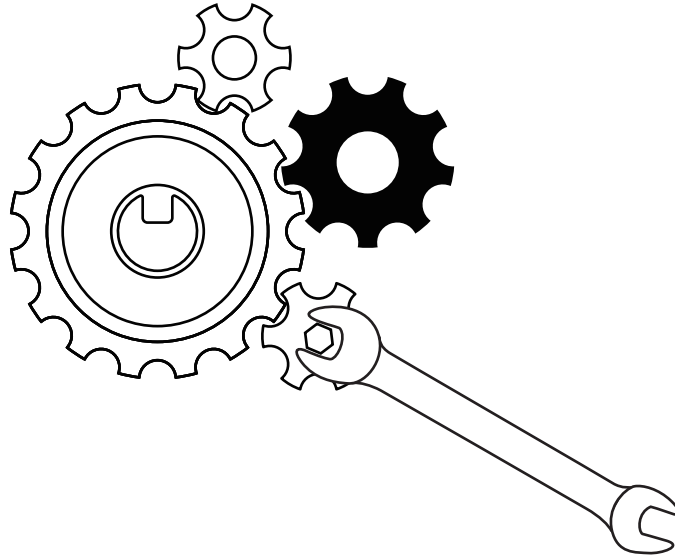

4、ASSEMBLING THE COMPONENTS

BICYCLE COMBINATION

Individual assembly guides for each bicycle model can be found packaged with your bicycle

GETTING STARTED

Open the carton from the top and remove the bicycle. Remove the straps and protective wrapping from the bicycle. Inspect the bicycle and all accessories and parts for possible shortages. It is recommended that the threads and all moving parts in the parts package be lubricated prior to installation. Do not discard packing materials until assembly is complete to insure that no required parts are accidentally discarded. Note: Your bicycle may be equipped with different style components than the ones illustrated.





SEAT POST CLAMP - QUICK RELEASE

Many ZIP and eZip bicycle models use quick release (QR) levers to facilitate common tasks such as frontwheel removal and seat height adjustment. When properly adjusted, quick release levers are both safe and convenient, but you must understand and apply the correct technique to adjust them properly before riding your bicycle to prevent serious injury or death from a fall. Quick release levers use a cam action to clamp the wheel or other components in place. Because of their adjustable nature, it is critical that you understand how they work, how to use them properly, and how much force you need to apply to secure them.

Warning: The full force of the cam action is needed to clamp the wheel securely. Holding the nut with one hand and turning the lever like a wing nut is NOT a safe or effective way to close a quick release and will not clamp the wheel or other components safely.

QUICK RELEASE USAGE

Riding with an improperly adjusted wheel quick release can allow the wheel to wobble or fall off the bicycle which can cause serious injury or death. Therefore, it is essential that you:

1. Ask your dealer or a local bike shop to help you make sure you know how to install and remove your wheels safely.
2. Understand and apply the correct technique for clamping your wheel in place with a quick release
3. Each time, before you ride the bike, check that the wheel is securely clamped.

ADJUSTING A QUICK RELEASE SEATPOST CLAMP

In a seatpost quick release system, the seatpost is clamped in place by the force of the quick release cam pushing against one side of the clamp and pulling the tension adjusting nut, by way of the skewer, against the other. The amount of clamping force is controlled by the tension adjusting nut. Turning the tension adjusting nut clockwise while keeping the cam lever from rotating increases clamping force; turning it counterclockwise while keeping the cam lever from rotating reduces clamping force. Less than half a turn of the tension adjusting nut can make the difference between safe clamping force and unsafe clamping force.

RIDING POSITION

Seat Height

In order to obtain the most comfortable riding position and offer the best possible pedaling efficiency, the seat height should be set correctly in relation to the rider's leg length. The correct saddle height should not allow leg strain from over-extension, and the hips should not rock from side to side when pedaling. While sitting on the bicycle with one pedal at its lowest point, place the ball of your foot on that pedal. The correct saddle height will allow the knee to be slightly bent in this position. If the rider then places the heel of that foot on the pedal, the leg should be almost straight.

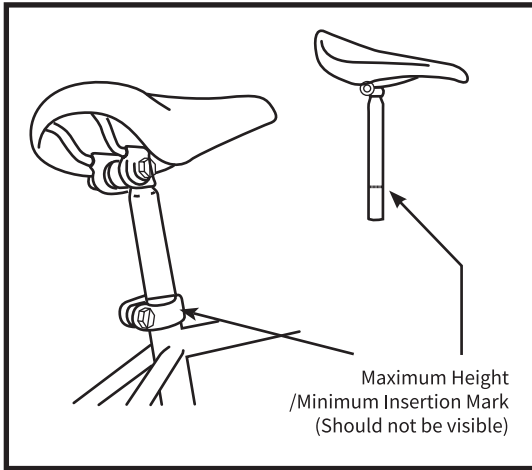

Under no circumstances should the seat post project from the frame beyond its “Minimum Insertion” or “Maximum Extension” mark. If your seat post projects from the frame beyond these markings, the seat post or frame may break, which could cause you to lose control and fall. Prior to your first ride, be sure to tighten the seat clamp properly. A loose seat clamp or seat post binder can cause damage to the bicycle or can cause you to lose control and fall. Periodically check to make sure that the seat clamp is properly tightened

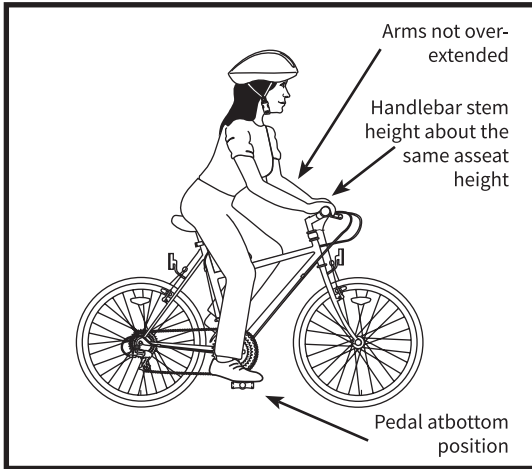

Reach

To obtain maximum comfort, the rider should not overextend his or her reach when riding.

To adjust this distance, the position of the seat can be altered in relation to the seat post. (Refer to page 66 on how to adjust the seat clamp.)

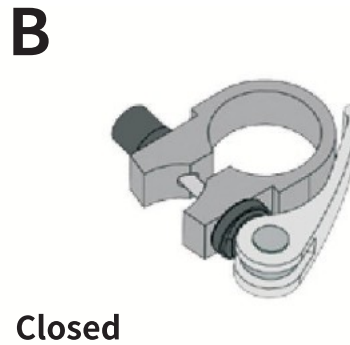
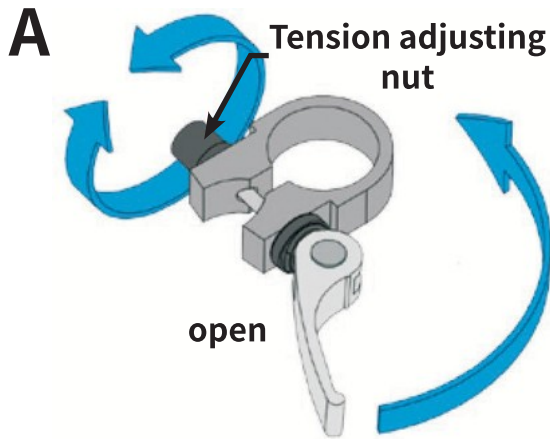

1. With the quick release clamp in the OPEN position, insert the seatpost, with saddle attached, into the bicycle's seat tube.
2. Swing the quick release lever into the CLOSED position
3. Grab the saddle with both hands and attempt to rotate it (and thus rotate the seatpost in the seat tube).
4. If you are able to force the seatpost out of alignment with the frame, the seatpost clamp needs to be adjusted. Holding the quick release lever in the OPEN position with one hand, tighten the tension adjusting nut with your other hand about 1/2 turn clockwise.
5. Attempt to swing the lever into the CLOSED position. If the lever cannot be pushed all the way to the CLOSED position (figure b), return the lever to the OPEN position, then turn the tension adjusting nut counterclockwise one-quarter turn and try tightening the lever again. Repeat steps 3, 4 & 5 until proper quick release tension is achieved.

FRONT WHEEL QUICK RELEASE

Installing a quick release front wheel

In a quick release system, the wheel hub is clamped in place by the force of the quick release cam pushing against one dropout and pulling the tension adjusting nut, by way of the skewer, against the other dropout. The amount of clamping force is controlled by the tension adjusting nut. Turning the tension adjusting nut clockwise while keeping the cam ever from rotating increases clamping force; turning it counterclockwise while keeping the cam lever from rotating reduces clamping force. Less than half a turn of the tension adjusting nut can make the difference between safe clamping force and unsafe clamping force.

1. Remove the tension adjusting nut and one of the small springs, then slide the quick release skewer through the hub, If your bicycle has a disc brake. insert the skewer starting on the side with the brake rotor, Replace the spring and tension adjusting nut (fig a).
2. If your bicycle has rim brakes, disengage them to increase the clearance between the tire and brake pads
3. Install the wheel into the dropouts, making sure the quick release lever is on the left side of the bicycle.
4. Holding the quick release lever in the OPEN position with one hand, tighten the tension adjusting nut with your other hand until it is snug against the fork dropout.
5. While pushing the wheel firmly to the top of the slots in the fork dropouts, and at the same time centering the wheel rim in the fork, move the quick-release lever upwards and swing it into the CLOSED position (fig b & c) The lever should now be parallel to the fork blade and curved toward the wheel. To apply enough clamping force, you should have to wrap your fingers around the fork blade for leverage, and the lever should leave a clear imprint in the palm of your hand.

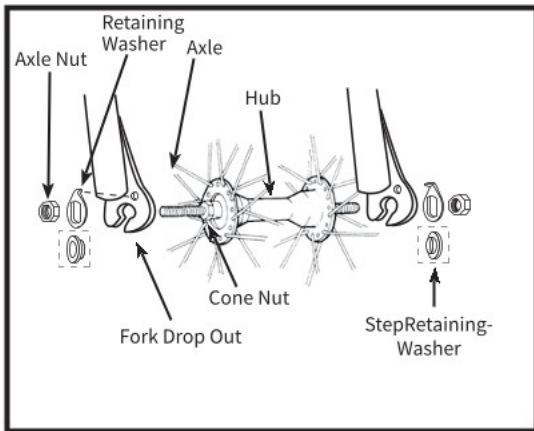

Front Wheel-Bolt-on installation

1. Make sure the brakes are loose enough to allow the wheel to pass through the brake pads easily.
2. Place wheel into fork dropouts.
3. Install retaining washers with raised lip pointed towards the fork, and insert into the small hole of the fork blade. **NOTE** Some bikes may have step retaining washers in place of the retaining washer (shown in dotted box). If so, install the step retaining washer, raised portion sliding in to the fork dropouts.
4. Install axle nut and tighten. Make sure the wheel is centered between the fork blades.
5. Spin the wheel to make sure that it is centered and clears the brake shoes. Tighten the brakes if necessary.

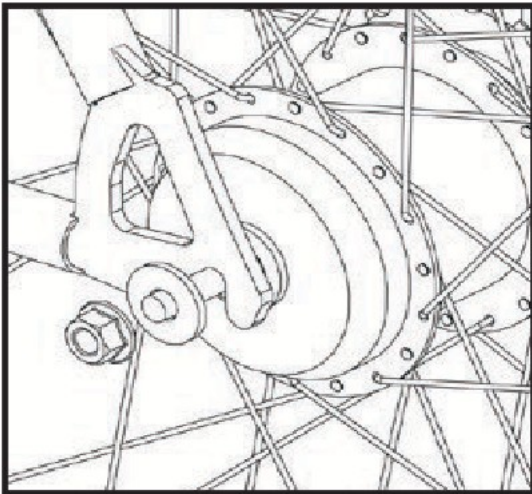

It is very important to check the front wheel connection to the bicycle. Failure to properly tighten may cause the front wheel to dislodge.

Rear Wheel- Bolt-on installation

1. If the bicycle has rim brakes, make sure the brakes are loose enough to allow the wheel to pass through the brake pads easily. For disc brakes, no adjustment is required.
2. Place the wheel into the frame dropouts.
3. Slide a washer onto each side of the axle.
4. Install axle nuts and tighten. Make sure the wheel is centered in the frame. This may be easiest with the bike turned upside-down.
5. Spin the wheel to make sure that it is centered and clears the brake shoes. Tighten the brakes if necessary.

Tighten both rear wheel axle nuts securely. Failure to do this may cause the rear wheel to dislodge from the frame dropouts resulting in serious damage or injury.

Periodically, disassemble the mechanism from the bicycle and inspect for any wear or damage and replace if necessary. When reinstalling, it is very important to ensure the connections are made properly.



Rear Wheel Bolt-on Removal

1. If the bicycle has rim brakes, make sure the brakes are loose enough to allow the wheel to pass through the brake pads easily. For disc brakes, no adjustment is required.
2. Most bikes have a plug or quick-disconnect box located on the seat stay or chain stay. These allow the motor to be easily disconnected from the controller. Simply undo the single large plug or open the black plastic box and undo the five plugs inside.
3. With the bicycle in a stand or upside-down, loosen the axle nuts then remove the wheel from the bicycle.



Disc Brakes - Tektro

1. Check the tightness of the six disc mounting bolts holding the brake rotor onto the wheel. If you need to remove these bolts, be sure to use a thread-locking compound when re-installing them.
2. Make sure the two bolts securing the caliper adaptor bracket to the fork are tight.
3. Thread the brake cable through the caliper as shown and secure it with the cable fixing bolt.
4. Loosen the two caliper mounting bolts enough to allow the brake caliper to float freely.

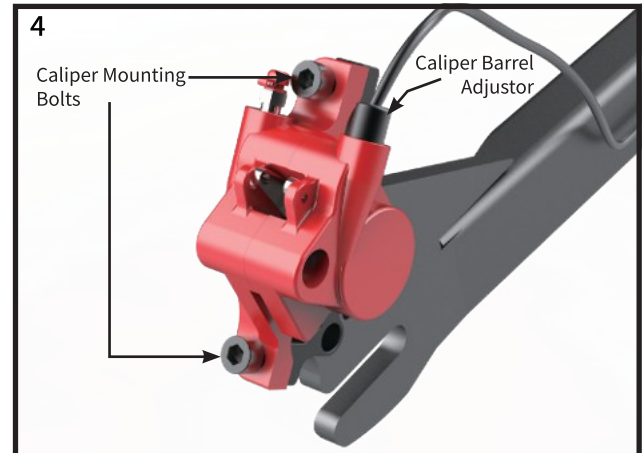
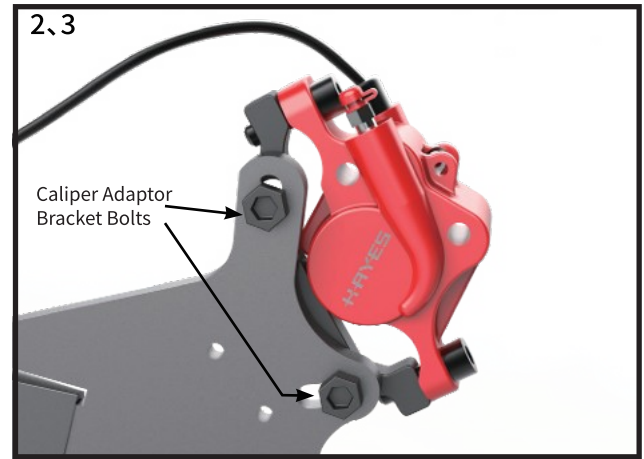

5. Install the wheel, making sure the brake rotor fits into the slot in the caliper. Center the caliper around the brake rotor, then tighten the caliper mounting bolts.
6. Using the inner pad adjusting bolt, adjust the inside brake pad so it is as close as possible to the rotor without rubbing.
7. Using the caliper barrel adjuster, adjust the outside brake pad so it is as close as possible to the rotor without rubbing.

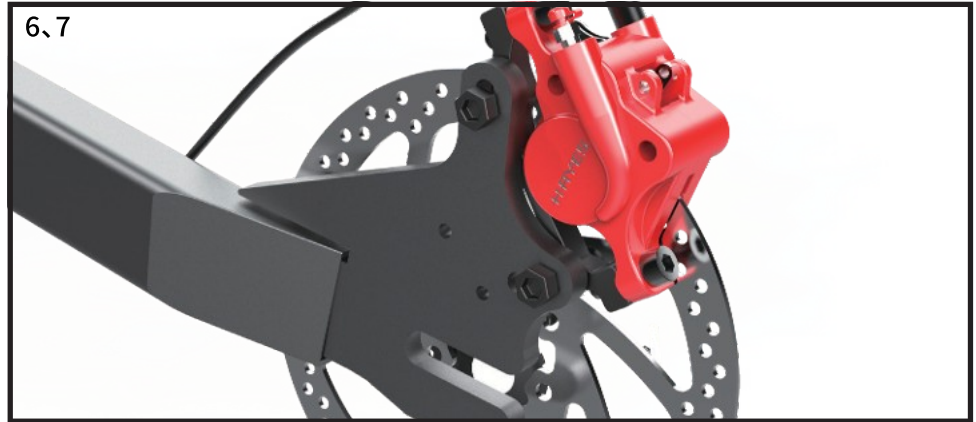
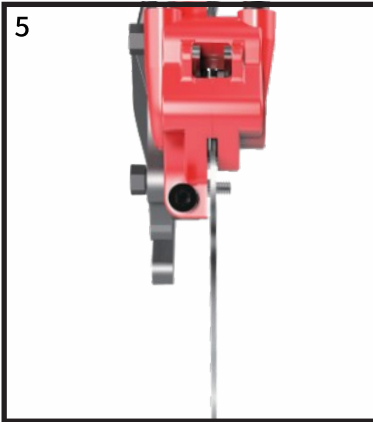

Disc brakes require breaking in. Ride and use the brakes gently for about 13 miles before using the brakes in downhill conditions, for sudden stops, or any other serious braking. Please be aware that your brake system will change in performance throughout the wear-in process. The disc brake should be cleaned before the first ride using rubbing alcohol. NEVER use oil or similar products to clean your disc brake system. Avoid touching the rotor (disc) with your fingers at any time. Naturally oily fingers can contaminate the rotor and/or the brake pads and diminish the brake's effectiveness. Brake rotors get hot! Severe injury could result from contact with the hot rotor. Mind your legs, as well as your hands.



DERAILLEUR SYSTEMS

The derailleur system includes the front and rear derailleurs, the shiftlevers, and the derailleur control cables, all of which must function correctly for smooth gear shifting to occur.

Derailleur

Although the front and rear derailleurs are initially adjusted at the factory, you will need to inspect and readjust both before riding the bicycle.

Rear Derailleur

Begin by shifting the rear shifter to largest number indicated, loosen the cable from the rear derailleur cable anchor bolt, and place the chain on the smallest sprocket.

Adjust the High limit screw so the guide pulley and the smallest sprocket are lined up vertically. Re-tighten the cable, pull out any slack, and retighten the anchor bolt securely. Shift through the gears, making sure each gear achieved is done quietly and without hesitation. If necessary, use the barrel-adjuster to fine tune the cable tension by turning it the direction you want the chain to go. For example, turning clockwise will loosen the cable tension and move the chain away from the wheel, while turning counter-clockwise will tighten cable tension and direct the chain towards the wheel.

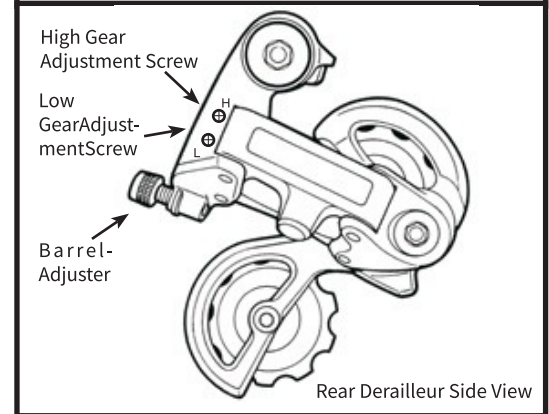
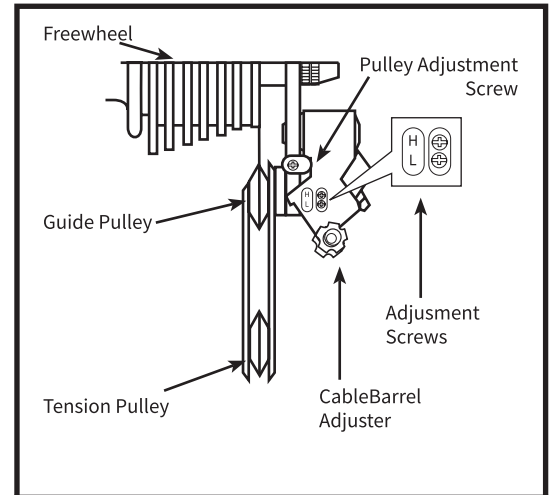

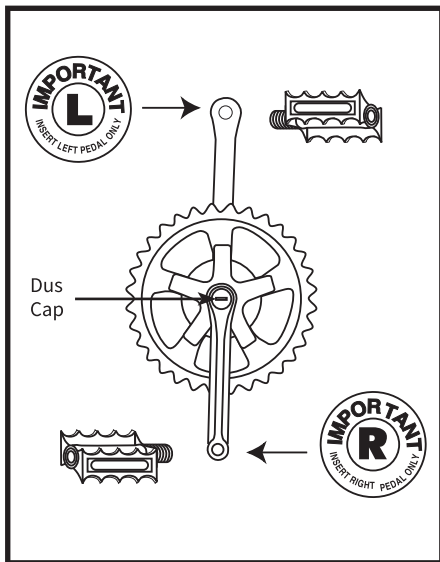

PEDALS & CRANK SET

Look for the letters “R” for right, and “L” for left, stamped on each pedalspindle. Start threading each pedal by hand to avoid stripping the threads. Tighten with a 15mm narrow open ended wrench. Note that the righthand pedal attaches to the chainwheel side crank arm with a right-hand (clockwise) thread. The left pedal attaches to the other crank arm and has a left-hand (counter-clockwise) thread. It is very important that you check the crank set for correct adjustment and tightness before riding your bicycle. New cranks may become loose with initial use, refer to pages 107-109 for proper crank set adjustment and maintenance. Once the pedals have been installed, remove the dust caps from the center of each crank arm. Tighten the spindle nuts securely (approx. 350 in. lbs.) with a 14mm socket wrench or an 8mm Allen wrench, depending on style, then replace the dust caps.

Attachment of an incorrect pedal into a crank arm can strip pedal threads and cause irreparable damage. Before your first ride, please check to insure your pedals are attached correctly.



Quick release levers use a cam action to clamp the wheel or other components in place. Because of their adjustable nature, it is critical that you understand how they work, how to use them properly, and how much force you need to apply to secure them. **Warning:** The full force of the cam action is needed to clamp the wheel securely. Holding the nut with one hand and turning the lever like a wing nut is NOT a safe or effective way to close a quick release and will not clamp the wheel or other components safely.

QUICK RELEASE USAGE

Riding with an improperly adjusted wheel quick release can allow the wheel to wobble or fall off the bicycle which can cause serious injury or death. Therefore, it is essential that you: 1. Ask your dealer or a local bike shop to help you make sure you know how to install and remove your wheels safely. 2. Understand and apply the correct technique for clamping your wheel in place with a quick release. 3. Each time, before you ride the bike, check that the wheel is securely clamped.

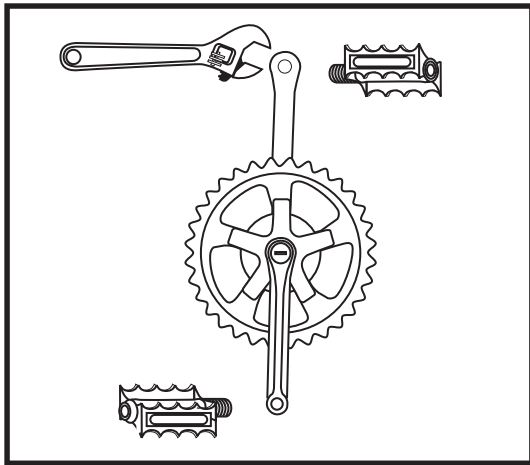

DRIVETRAIN

The drivetrain of a bicycle refers to all parts that transmit power to the rear wheel including the pedals, chain, chainwheel, crank set and freewheel.

Pedals

Pedals are available in a variety of shapes, sizes and materials, and each are designed with a particular purpose in mind. Some pedals can be fitted with toe clips and straps. These help to keep the feet correctly positioned and allow the rider to exert pulling force, as well as downward pressure, on the pedals. Use of toe clips with straps requires practice to acquire the necessary skill to operate them safely.

Inspection

Pedals should be inspected every month, taking note of the following areas:

- Check correct tightness into the crank arms. allowed to become loose, they will not only be dangerous but will also cause irreparable damage to the cranks.
- Check that pedal bearings are properly adjusted. pedals up and down, and right to left, and also rotate them by hand. If you detect any looseness or roughness in the pedal bearings then adjustment, lubrication or replacement is required.
- Ensure that the front and rear pedal reflectors are securely fitted.
- Also ensure that the toe clips, if fitted, are securely fitted to the pedals.

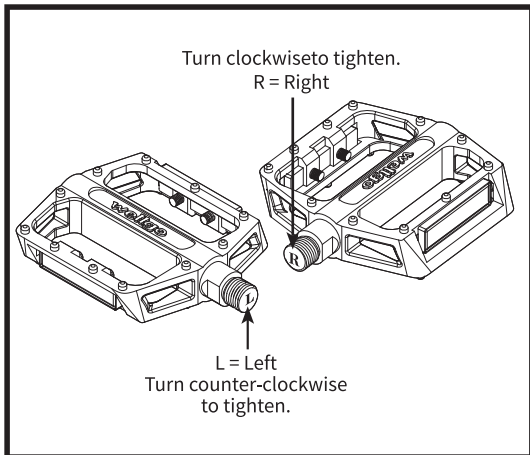

Never ride with loose pedals



5. MAINTENANCE AND REPAIR

Correct routine maintenance of your new bike will ensure smooth running Longer lasting components - Safer riding - Lower running costs

Every time you ride your bicycle, its condition changes. The more you ride, the more frequently maintenance will be required. We recommend you spend a little time on regular maintenance tasks. The following schedules are a useful guide and by referring to Part 6 of this manual, you should be able to accomplish most tasks. If you require assistance, we recommend you see a bicycle specialist.

Schedule 1 - Lubrication

Frequency	Component	Lubricant	How to Lubricate
Weekly	Chain	Chain Lube or Light Oil	Brush On or Squirt
	Derailleur Pulleys	Chain Lube or Light Oil	Brush On or Squirt
	Derailleurs	Oil	Oil Can
	Brake Calipers	Oil	3 drops from oil can
	Brake Levers	Oil	2 drops from oil can
Monthly	Shift Levers	Lithium Based Grease	Disassemble
Every Six Months	Freewheel	Oil	2 squirts from oil can
	Brake Cables	Lithium Based Grease	Disassemble
Yearly	Bottom Bracket	Lithium Based Grease	Disassemble
	Pedals	Lithium Based Grease	Disassemble
	Derailleur Cables	Lithium Based Grease	Disassemble
	Wheel Bearings	Lithium Based Grease	Disassemble
	Headset	Lithium Based Grease	Disassemble
	Seat Post	Lithium Based Grease	Disassemble

Problem	Possible Cause	Remedy
Gear shifts not working properly	<ul style="list-style-type: none"> - Derailleur cables sticking/stretched/damaged - Front or rear derailleur not adjusted properly - Indexed shifting not adjusted properly 	<ul style="list-style-type: none"> - Lubricate/tighten/replace cables - Adjust derailleurs - Adjust indexing
Slipping chain	<ul style="list-style-type: none"> - Excessively worn/chipped chainring or freewheel sprocket teeth - Chain worn/stretched - Stiff link in chain - Non-compatible chain/chainring/freewheel 	<ul style="list-style-type: none"> - Replace chainring, sprockets and chain - Replace chain - Lubricate or replace link 1 - Seek advice at a bicycle shop
Chain jumping off freewheel sprocket or chainring	<ul style="list-style-type: none"> - Chainring out of true - Chainring loose - Chainring teeth bent or broken - Rear or front derailleur side-to-side travel out of adjustment 	<ul style="list-style-type: none"> - Re-true if possible, or replace - Tighten mounting bolts - Repair or replace chainring/set - Adjust derailleur travel
Constant clicking noises when pedaling	<ul style="list-style-type: none"> - Stiff chain link - Loose pedal axle/bearings - Loose bottom bracket axle/bearings - Bent bottom bracket or pedal axle - Loose crankset 	<ul style="list-style-type: none"> - Lubricate chain / Adjust chain link - Adjust bearings/axle nut - Adjust bottom bracket - Replace bottom bracket axle or pedals - Tighten crank bolts
Grinding noise when pedaling	<ul style="list-style-type: none"> - Pedal bearings too tight - Bottom bracket bearings too tight - Chain fouling derailleurs - Derailleur jockey wheels dirty/binding 	<ul style="list-style-type: none"> - Adjust bearings 1 - Adjust bearings" - Adjust chain line - Clean and lubricate jockey wheels

Problem	Possible Cause	Remedy
Freewheel does not rotate	<ul style="list-style-type: none"> - Freewheel internal pawl pins are jammed 	<ul style="list-style-type: none"> - Lubricate. If problem persists, replace freewheel
Brakes not working effectively	<ul style="list-style-type: none"> - Brake blocks worn down - Brake blocks/rim greasy, wet or dirty - Brake cables are binding/stretched/damaged - Brake levers are binding - Brakes out of adjustment 	<ul style="list-style-type: none"> - Replace brake blocks - Clean blocks and rim - Clean/adjust/replace cables - Adjust brake levers - Center brakes
When applying the brake they squeal/squeak	<ul style="list-style-type: none"> - Brake blocks worn down - Brake block toe-in incorrect - Brake blocks/rim dirty or wet - Brake arms loose 	<ul style="list-style-type: none"> - Replace blocks - Correct block toe-in - Clean blocks and rim - Tighten mounting bolts
Knocking or shuddering when applying brakes	<ul style="list-style-type: none"> - Bulge in the rim or rim out of true - Brake mounting bolts loose - Brakes out of adjustment - Fork loose in head tube 	<ul style="list-style-type: none"> - True wheel or take to a bike shop for repair - Tighten bolts - Center brakes and/or adjust brake block toe-in - Tighten headset
Wobbling wheel	<ul style="list-style-type: none"> - Axle broken - Wheel out of true - Hub comes loose - Headset binding - Hub bearings collapsed - QR mechanism loose 	<ul style="list-style-type: none"> - Replace axle - True wheel - Adjust hub bearings - Adjust headset - Replace bearings - Adjust QR mechanism

Problem	Possible Cause	Remedy
Steering not accurate	<ul style="list-style-type: none"> - Wheels not aligned in frame - Headset loose or binding - Front forks or frame bent 	<ul style="list-style-type: none"> - Align wheels correctly - Adjust/tighten headset - Take bike to a bike shop for possible frame realignment
Frequent punctures	<ul style="list-style-type: none"> - Inner tube old or faulty - Tire tread/casing worn - Tire unsuited to rim - Tire not checked after previous puncture - Tire pressure too low - Spoke protruding into rim 	<ul style="list-style-type: none"> - Replace Inner tube - Replace tire - Replace with correct tire - Remove sharp object embedded in tire - Correct tire pressure - File down spoke

This manual contains important safety, performance and maintenance information.
Please read this manual before riding your new bike for the first time and keep the
manual in a safe place for future reference.



DONGGUAN XINGJI OUTDOOR SPORTS CO.,LTD